

— : φ 8 (t1.0) COPPER PIPE
— : φ 6 AIR TUBE

V.D.R.
(in Cont. Room)



ALARM PANEL
(in W/H)



POWER SOURCE
AC100 ~ 220V

DRY AIR
(YARD SUPPLY)

SIGNAL OUTPUT
TO Monitor

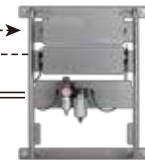

LAX-ADM



12 SETS

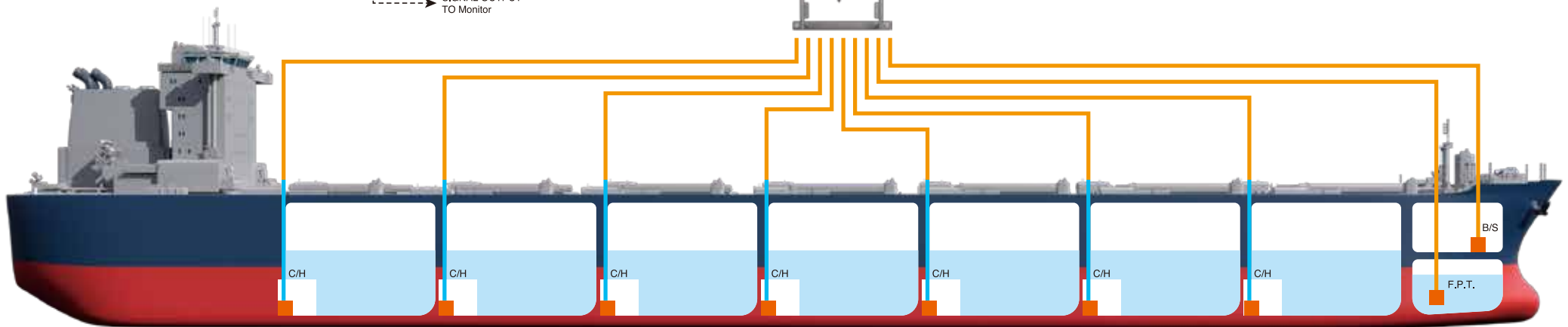

CARGO HOLD

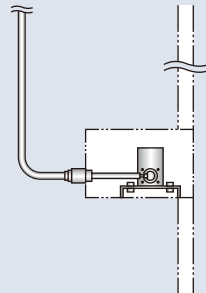

F.P.T.

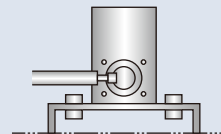

B/S

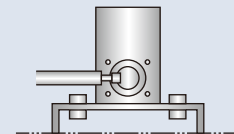

— : φ 8 (t1.0) COPPER PIPE
 — : 20A PIPE (YARD SUPPLY)



V.D.R.(in Cont. Room)

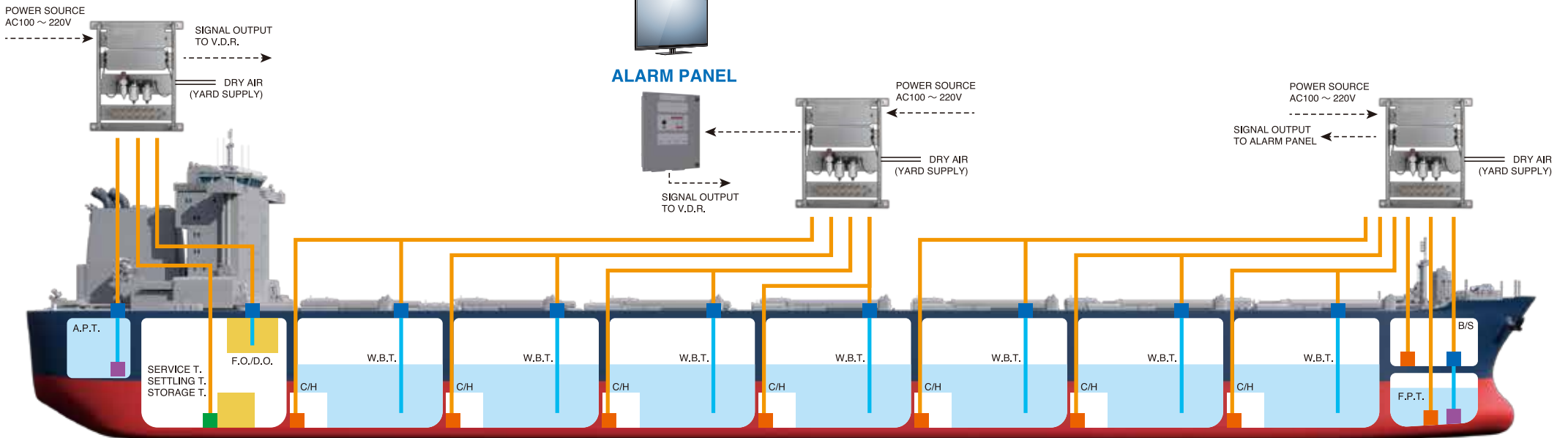

SERVICE T./SETTLING T./STORAGE T.

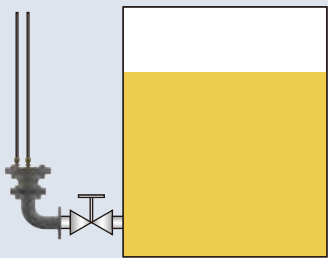

INGRESS ALARM

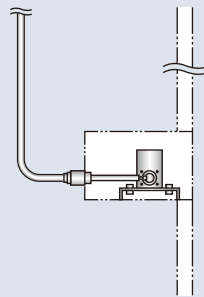

W.B.T. / F.P.T. / A.P.T.

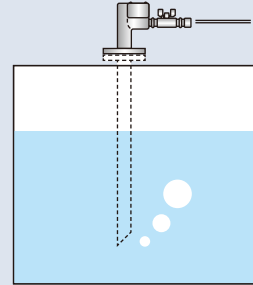

DRAFT GAUGE

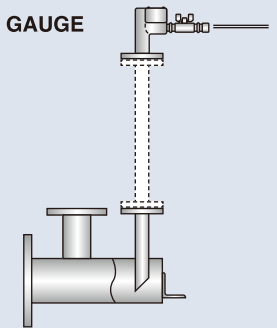

— : φ 8 (t1.0) COPPER PIPE
 — : 20A PIPE (YARD SUPPLY)

LAX-PH



54 SETS

LAX-WAC



8 SETS

LAX-ADM



70 SETS

DRAFT CHAMBER



4 SETS

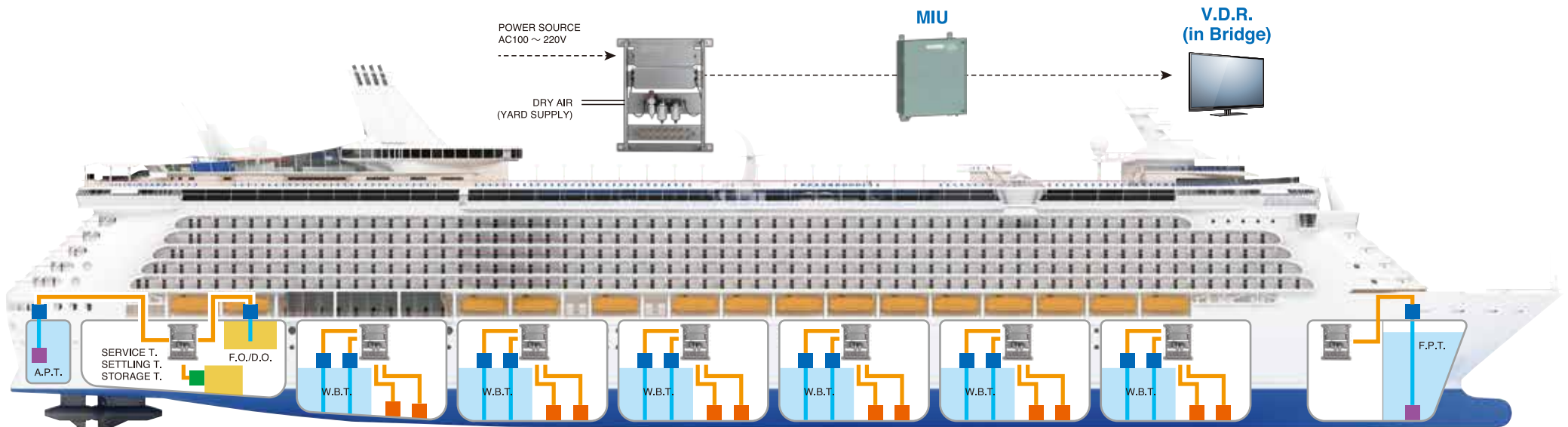

**SERVICE TANK
 SETTling TANK
 STORAGE TANK**

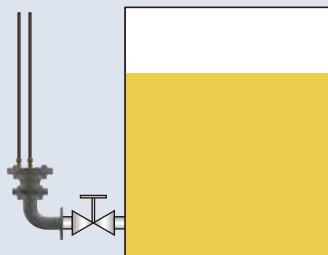

BILGE ALARM

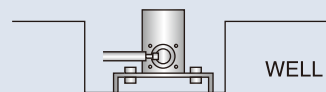

W.B.T. / F.P.T. / A.P.T.

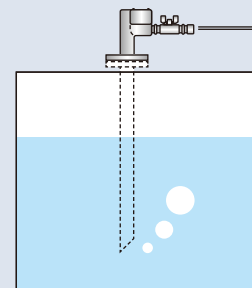

DRAFT GAUGE

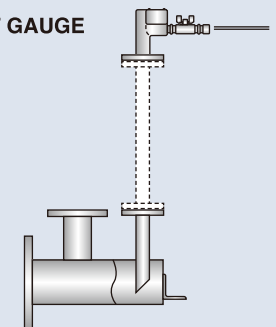

— : φ 6 AIR TUBE

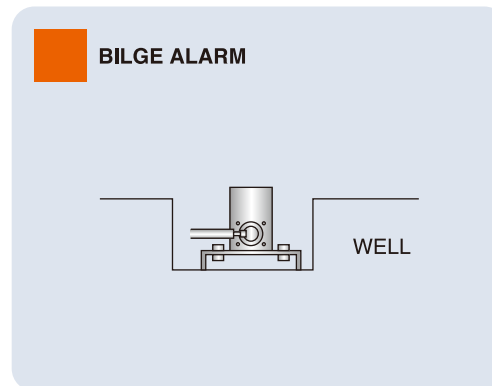
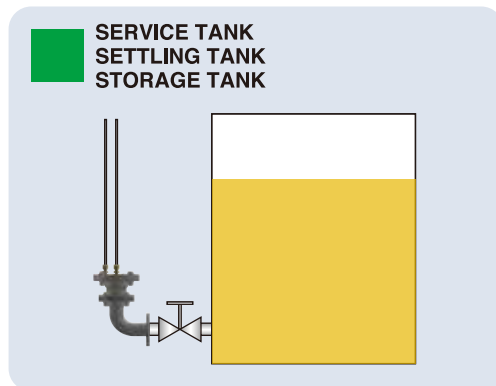
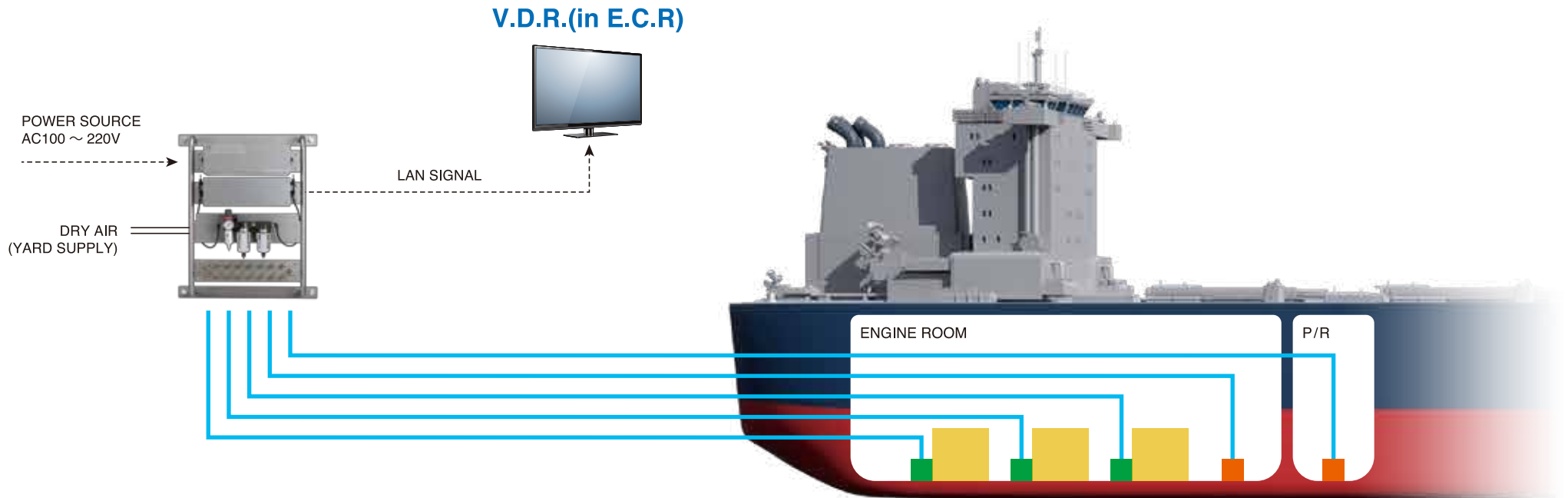

— : φ 8 (t1.0) COPPER PIPE
 — : 20A PIPE (YARD SUPPLY)

LAX-PH



16 SETS

LAX-WAC



6 SETS

LAX-ADM



4 SETS

DRAFT CHAMBER



2 SETS

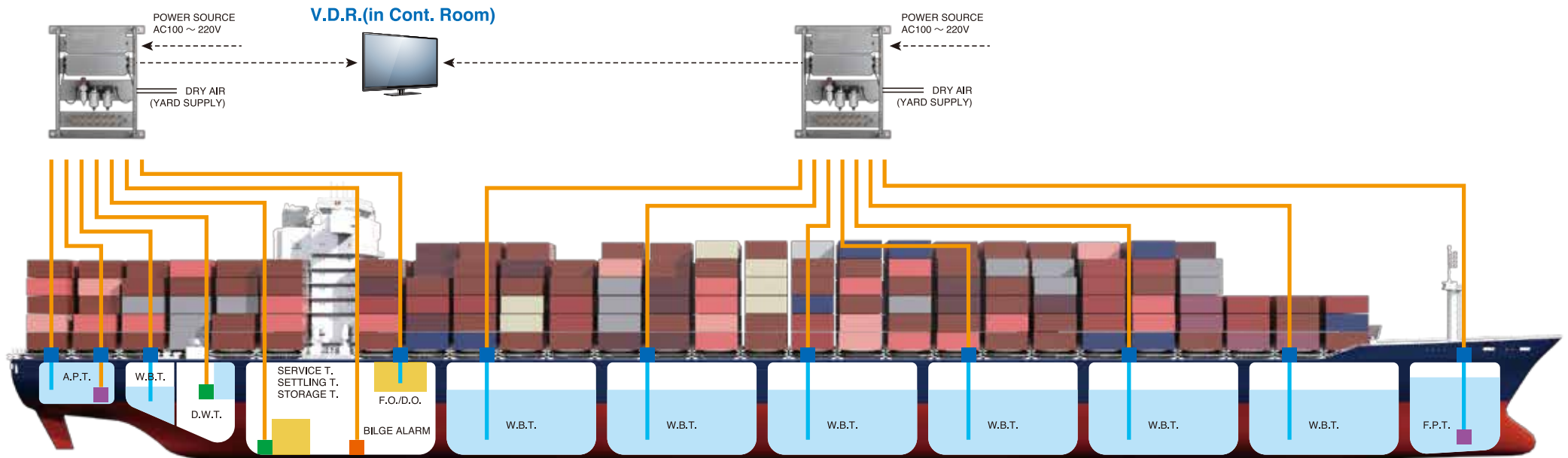

LAX-WAC

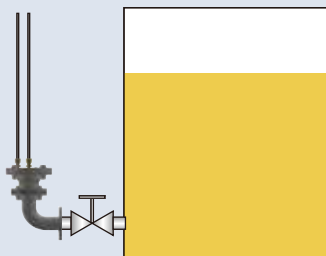

BILGE ALARM

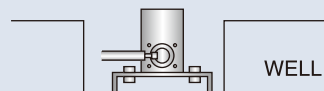

W.B.T. / F.P.T. / A.P.T.

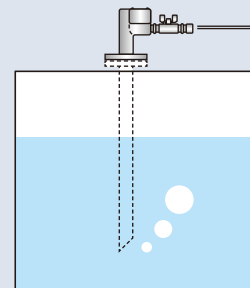

DRAFT GAUGE

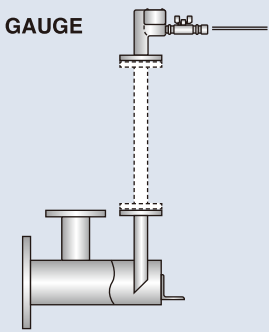

— : φ 8 (t1.0) COPPER PIPE
 — : 20A PIPE (YARD SUPPLY)

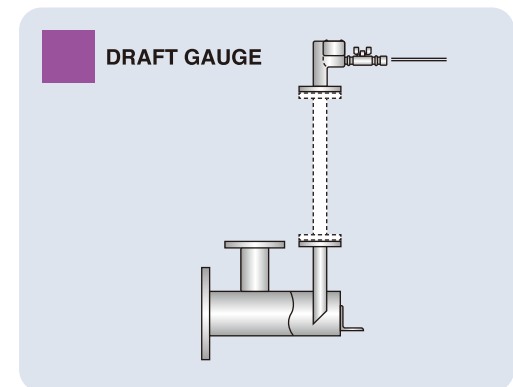
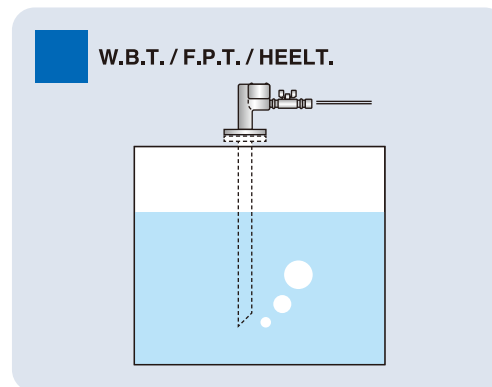
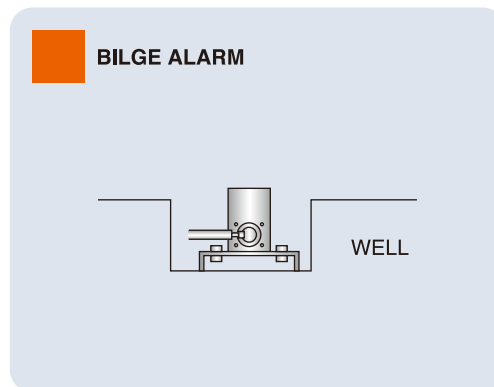
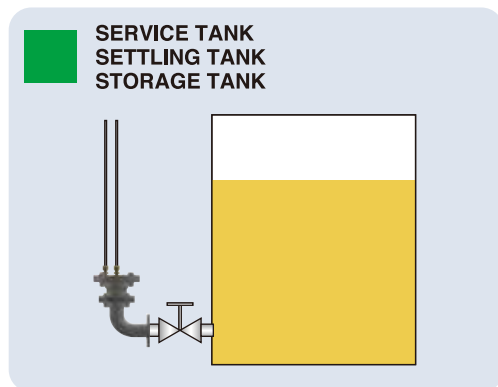
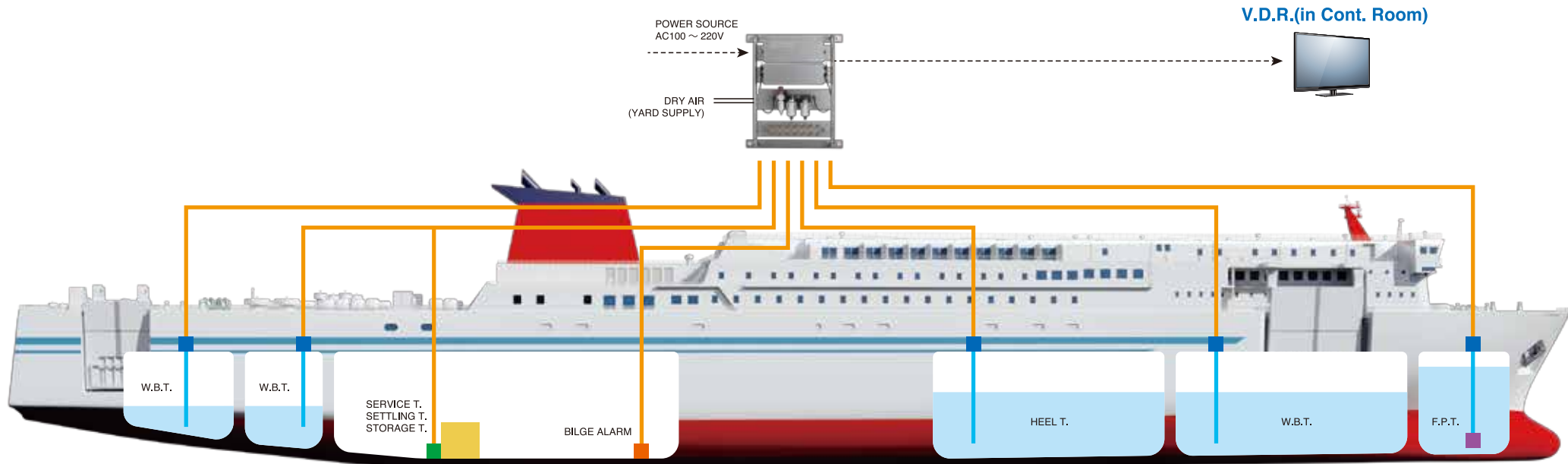

パルスパーズ式液面計で高精度な計測 ±10mm

オートトリム/ヒール機能で最適な喫水とバラスト重量を計算*1

ソフトMIMIC(誤操作防止&操作プレイバック機能)で遠隔バルブ操作



● 作業人員の削減

● 作業時間の軽減

● 燃費効率アップ*2

*1 Loading Computerで積付計算用のデータ登録が必要です。

*2 実績DB参照により、最適トリムでの運航が可能。燃費効率アップが期待できます。

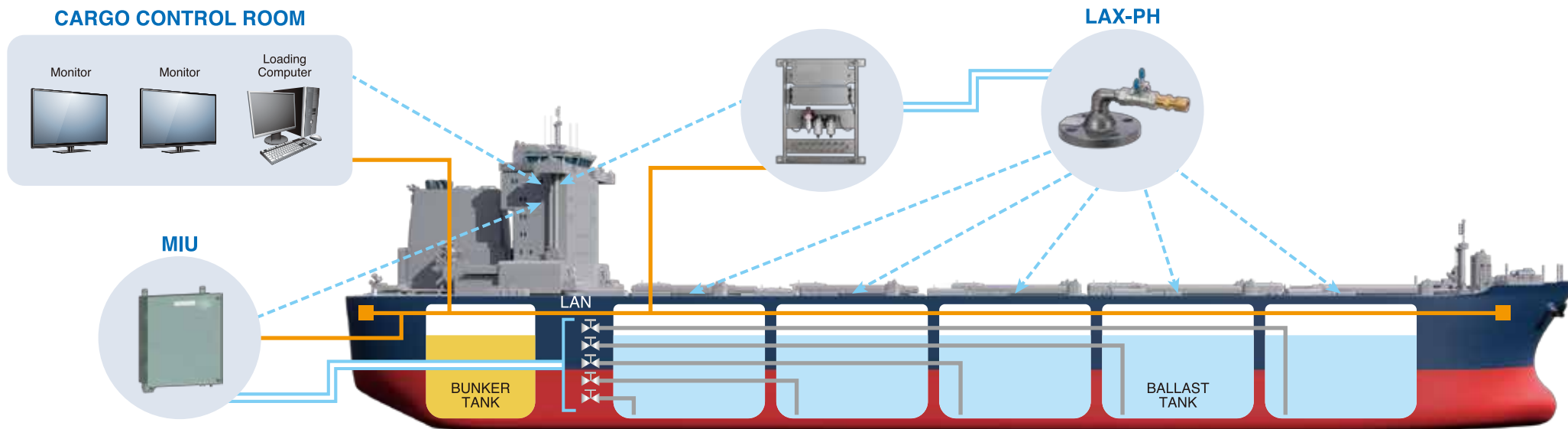

従来の作業手順

- ① インクリノメータで傾きを確認
- ② サウンディングテープでの液面計測
- ③ バラストタンクのバルブを手動開閉
- ④ 上記作業の繰り返し



- ☑ 作業人員が多い
- ☑ 作業時間が長い
- ☑ 最適なバラストイングが難しい

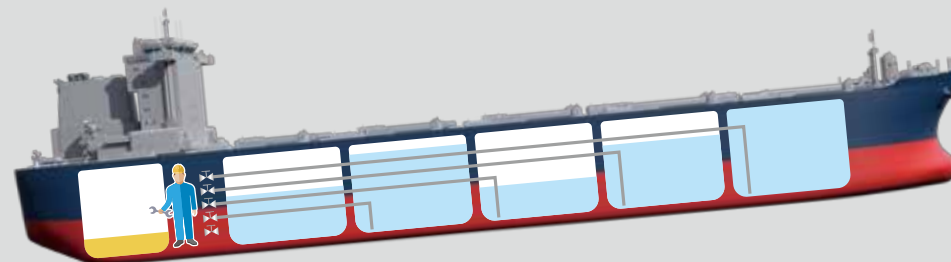

船体ストレスを監視

船側の作業

- ① ローディングコンピュータにて荷役を実施
- ② 船体ストレス監視アプリが定期的に強度計算を実施
- ③ 船体ストレス状況を視覚的に確認
- ④ フレーム表示が異常を示す場合は、積付計画を変更
- ⑤ リモートメンテナンスアプリが強度計算結果を送信

陸側の作業

- ① 船体ストレス監視アプリで安全性を確認(過去～現在)
- ② 蓄積された船体ストレスデータを基に船の負荷履歴を評価値に換算

データ共有

作業時間の軽減

安全性の確保

船体評価値の取得

CARGO CONTROL ROOM

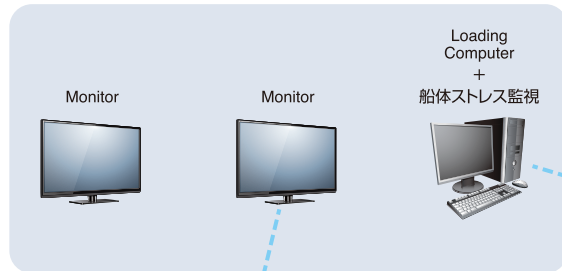

通信衛星



陸上Office(船舶管理)



通信機

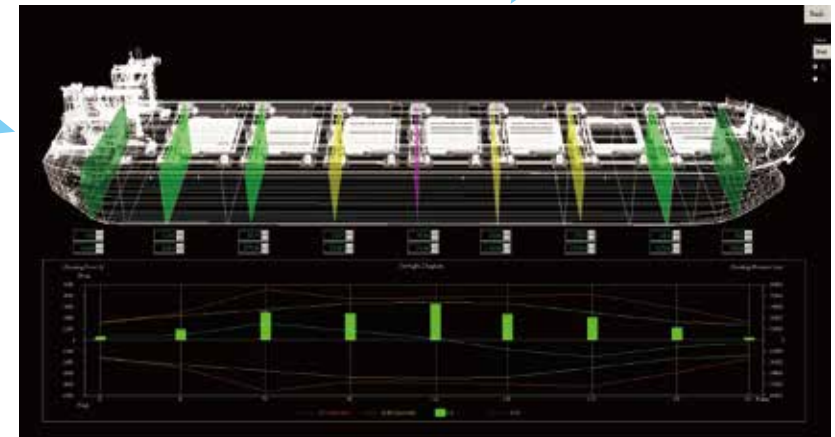
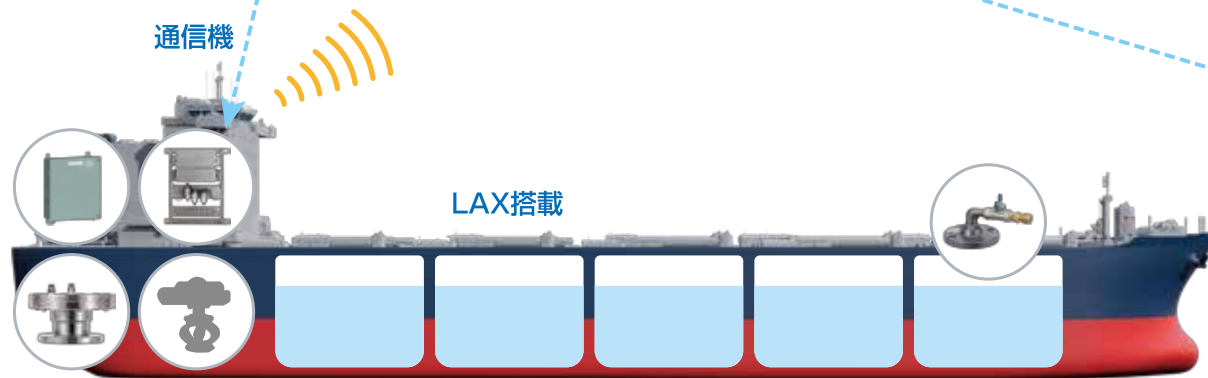

ムサシノ機器株式会社

□ 本社 〒145-0066 東京都大田区南雪谷1-2-15
Tel.03-3726-4413 Fax.03-3726-1557
Email : sales@musasino.co.jp / service1@musasino.co.jp
<https://www.musasino.biz>